

CP- ENC-V21L3-DS

2 MP Full HD WDR IR Vandal Dome Camera - 30Mtr.

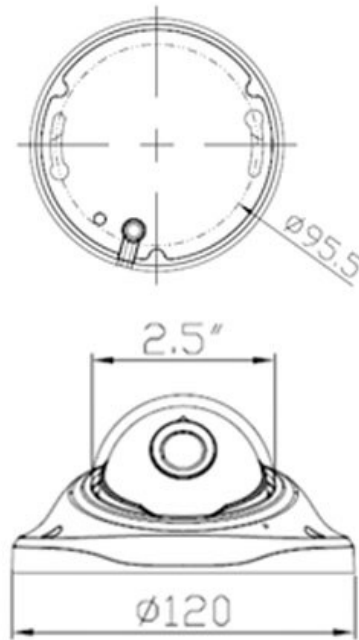

Main Features

- 1/2.7" 2MP CMOS Image Sensor
- Max 25fps@2MP
- H.265/ H.264 Video Compression
- WDR(100dB), Day/Night (ICR), AWB, AGC, BLC
- 3.6mm lens (6mm optional)
- IR Range of 30 Mtrs, IP66
- Mobile Software: RMOB
- CMS Software: RVMS



*Product casing and specifications are subject to change without prior notice

CP- ENC-V21L3-DS

2 MP Full HD WDR IR Vandal Dome Camera - 30Mtr.



Feature

Image Sensor
Minimum Illumination
White Balance
Gain Control (AGC)
Lens
Back Light Compensation
Video Compression
Video Streaming
Resolution
Frame Rate
ICR
WDR
Protocol
Ethernet
IR
Smart Phone
Operating Temperature
Power Source
Weatherproof Standard
Dimension
Weight

Specification

1/2.7" 2MP CMOS Image Sensor
0.01Lux@F1.2(Color)/0.001Lux@F1.2(B/W)
Auto/Manual
Auto/Manual
3.6mm Lens (6mm optional)
Auto/Manual
H.265 / H.264
Dual Stream
1080P(1920×1080) / 720P(1280×720) / D1(704×576) / CIF(352×288)
Main Stream : 1080P@25fps , Sub-Stream: D1
IR CUT
WDR (100dB)
ONVIF Support (profile S)
RJ-45 (10/100Base-T)
IR Range of 30 Mtr.
iPhone, iPad, Android
-20°C~+65°C
DC12V±10%, PoE
IP66
120mm x 62mm
290g